

collector current of a phototransistor constant over a temperature range from 20 to 90°C.

The temperature compensation in the base circuit may be accomplished by using a thermistor or even another germanium device. If the dark current is maintained at a constant value, the threshold sensitivity of the output device may be set at a value just slightly above the dark current, maintaining a uniformly high sensitivity over the operating range. Figure 16.27 shows a simple temperature-compensated photorelay device.

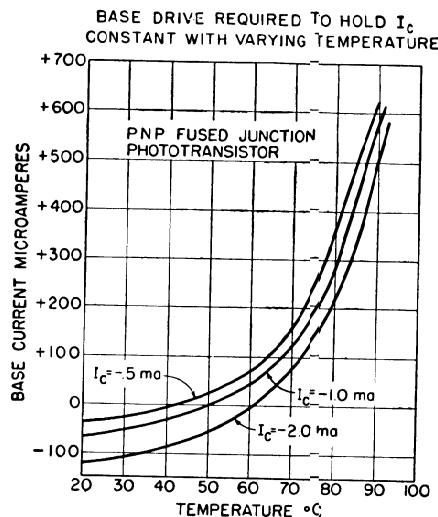

FIG. 16.26. Base drive required to hold I_c constant with varying temperature.

There is no collector output current until the transistor is illuminated, when the light biases the transistor into the active conduction region. The output current is also an a-c wave which can be capacitively coupled to an a-c amplifier or detector. This system does not have the sensitivity obtained when the light beam only is modulated because in the electrical method of modulation the temperature-

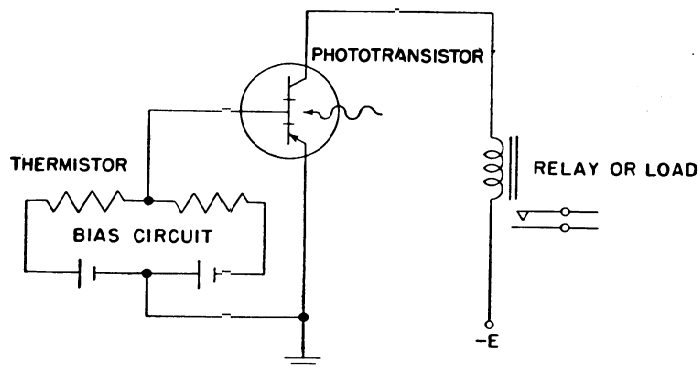

FIG. 16.27. Temperature-compensated photorelay.

variant dark current is also modulated along with the light-sensitive component. The a-c load circuit cannot distinguish between the a-c component due to illumination and the alternating current due to temperature variations. However, this example provides an illustration of the increased flexibility obtained with a phototransistor when both the electrical and optical inputs are available. Probably the largest single

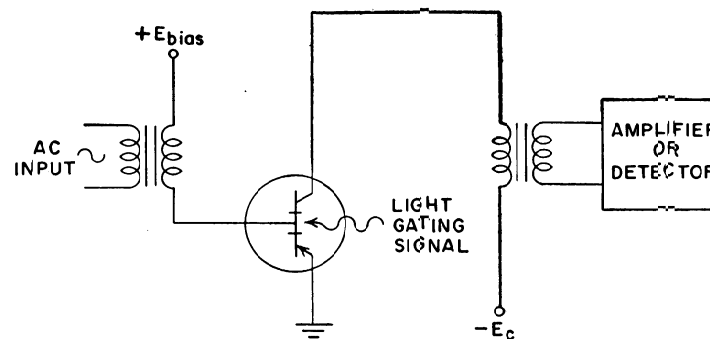

FIG. 16.28. Gating phototransistor detector.

advantage gained is the ability to compensate for the temperature variations in dark current and maintain the sensitivity nearly constant.

If all the photodevices described are subjected to a uniform illumination, the response of each device will be proportional to both the active area and the sensitivity in milliamperes per millilumen. Table 16.1 provides a summary of the properties of photoconducting devices by comparing the total photoresponsive output current, an important consideration to the circuit designer. Several vacuum-type photodevices are also included to assist the comparison.

TABLE 16.1 COMPARISON OF SENSITIVITY AND RESPONSE OF VARIOUS PHOTODETECTORS TO INCANDESCENT LIGHT

Photodetector	Dark current, μa	Sensitive area of typical units, in. ²	Sensitivity, amp/lumen	Net response to flux of 0.1 lumen/in. ² (14.4 ft C), μa
929 vacuum phototube.....	0.0125	0.507	45 μa /lumen	2.28
931A photomultiplier.....	0.1	0.293	20	586,000
1P22 photomultiplier.....	0.25	0.293	0.6	17,600
Photodiode (point contact)...	1-3 ma	(0.0009)	0.1	9
Photodiode (junction).....	1-10	(0.0009)	0.03	2.7
Hook collector photodiode (fused junction).....				7,200
Phototransistor (NPN grown junction).....	10-100	(0.0009)	3	270
Phototransistor (PNP fused junction).....	1-10	0.00155	2.3	360

16.5. The Inverted Transistor. The low conduction resistance and low leakage currents of the fused-junction transistor have suggested many applications utilizing the transistor as a controlled switch.¹⁰ When conducting, such transistor switches may have equivalent resistances of a few ohms, and when cut off they may exhibit impedances of a few hundred kilohms to several megohms. Where the voltages and currents to be controlled are small in magnitude, the performance of such fused-junction transistor switches may be greatly improved by utilizing interesting and different circuit configurations with the transistor in the inverted connection.^{9,10} As the name implies, the emitter and collector connections of the transistor are inverted or inter-

changed, so that the electrode normally labeled as the collector functions as the emitter, and vice versa. The changes in the characteristics so obtained are of sufficient importance to warrant the consideration of the inverted transistor as a separate device.

Fused-junction transistors are usually manufactured with a collector of a somewhat larger size than the emitter in order to obtain a high value of current gain α . This construction assures that nearly all the minority carriers which diffuse through the base region are collected even if some radial spreading occurs, thus improving the current gain. However, either the collector or emitter is capable of emitting minority carriers into the base region, and the remaining electrode can function to collect the carriers. Because of the different relative geometry when the collector functions as the emitter, and vice versa, the transistor would have a different value of inverted current gain than the normal current gain. It is possible, of course, to construct symmetrical transistors, such that both current gains would be equal, but this usually involves some compromise on maximum normal current gain. When the emitter is biased with a reverse voltage, its leakage current with the collector open circuited, I_{e0} , is usually lower than I_{c0} for the same transistor, because of the smaller size of the emitter.

In the definitions and discussions that follow it will be assumed that one rectifying contact has been marked the emitter and the other has been marked the collector by the manufacturer. The electrodes will be referred to by these markings rather than by their actual circuit function. The two different current gains possible, depending on the transistor connection, are defined as:

- α_N = transistor current gain with the emitter functioning as an emitter and the collector functioning as a collector (normal alpha)
 α_I = transistor current gain with the collector functioning as an emitter and the emitter functioning as a collector (inverted alpha)

Most commercial transistors have an α_N between 0.9 and 0.999, while α_I is only about 0.3 to 0.6. The collector leakage current I_{c0} and the corresponding emitter leakage current I_{e0} are not independent of each other but have been shown⁹ to be interrelated by the expression

$$\alpha_N I_{e0} = \alpha_I I_{c0} \quad (16.3)$$

Thus for the ranges of α_N and α_I given above, I_{e0} may vary from 0.3 to 0.67 I_{c0} .

Since α_N is usually higher than α_I , much higher current gains and power-handling capacities are available when using the transistor in the normal connection. The advantages of the inverted connection are most apparent in applications where junction transistors are used to control very low power levels.

Figure 16.29 shows a family of collector-characteristic curves for a common-emitter connection. The transistor curves usually shown for this connection appear in the third quadrant. Note that operation with reversed polarity on the emitter and collector is possible in the first quadrant and that the curves show similar transistor action except that the current gain is much smaller. If the base conditions of this transistor are switched from -3 ma to $+1$ volt, the collector-emitter characteristics near the origin are two lines which are nearly parallel to the axes and which intersect at a point $P_N(V_P^N, I_P^N)$ in the third quadrant. The characteristics of an ideal switch would simply be two lines coincident with the axes, one along the current axis corresponding to the closed switch, the other along the voltage axis corresponding to an open circuit. Thus the transistor is nearly equivalent to an ideal switch in series with a battery V_P^N and shunted by a current source I_P^N . The battery and current source limit the lowest load voltage and current levels that the transistor can switch without introducing extraneous signals comparable with the controlled load signals. If the point P is brought closer to the origin, lower levels of load voltage and current may be

controlled satisfactorily. R. L. Bright¹⁰ has shown that this equivalent battery and current source are given by

$$I_P^N = \frac{(1 - \alpha_I)I_{c0}}{1 - \alpha_N\alpha_I} \quad (16.4)$$

$$V_P^N = \frac{kt}{q} \ln \frac{1}{\alpha_I} \quad (16.5)$$

If the collector and emitter terminals are interchanged (Fig. 16.30) so that the transistor is operated in an inverted connection, the corresponding intersection point P_I of the resulting characteristics is several orders of magnitude nearer the origin. Bright

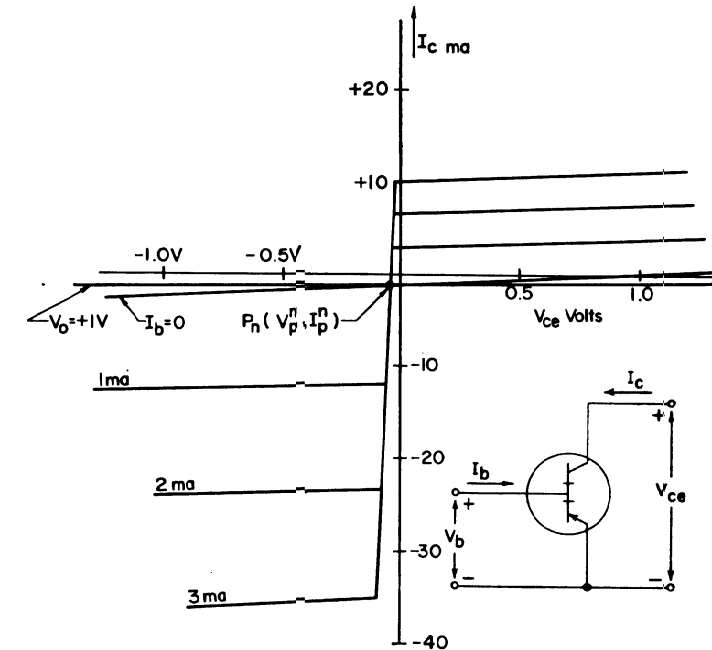

FIG. 16.29. Collector-characteristic curves for a common-emitter connection. (Redrawn by permission of the American Institute of Electrical Engineers.)

gives the corresponding coordinates for the inverted connection, which could also be obtained by considering the effect of inverted terms in Eqs. (16.4) and (16.5). (Figure 16.31 shows the equivalent circuit for an inverted transistor switch.) These coordinates are

$$I_P^I = \frac{(1 - \alpha_N)I_{e0}}{1 - \alpha_N\alpha_I} \quad (16.6)$$

$$V_P^I = \frac{kt}{q} \ln \frac{1}{\alpha_N} \quad (16.7)$$

Thus while I_{e0} is lower than I_{c0} by a factor of 0.3 to 0.67, I_P^I is even lower than I_P^N by the additional factor of $(1 - \alpha_N)$ compared to $(1 - \alpha_I)$. For a fused-junction PNP germanium transistor, typical values for the coordinates of P_N are V_P^N equals -10 to -40 mv and I_P^N equals -40 μ a, while those of P_I are reduced to V_P^I equals -0.5 to -1.5 mv and I_P^I equals -1 to -2 μ a. Thus the inverted connection offers improved characteristics wherever low signal levels are encountered since the values of the

spurious signals introduced by the transistor switch are reduced by orders of magnitude.

In using the inverted transistor as a controlled switch, the current which can be passed through the switch is determined by the inverted gain α_I of the transistor. This inverted gain $\alpha_I = I_e/I_c$ is usually about 0.5 for commercially available transistors, giving a base-to-emitter current gain of about unity. Thus $I_e = I_b\alpha_I/(1 - \alpha_I)$ is limited to the same current value as I_b . Since most applications of the inverted connection will be made at low current levels, this low gain is of no serious consequence,

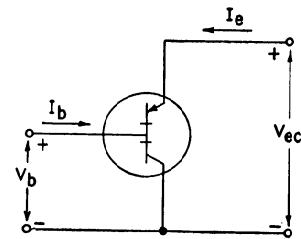

FIG. 16.30. Inverted connection.

and the base-drive switching source will usually be capable of supplying adequate base drive. Base-to-emitter gains of unity for emitter currents as high as 15 ma are available in commercial transistors. Higher values of gain may be obtained in symmetrical transistors, usually with an accompanying increase in I_P . As a consequence of the reduced value of I_P for the inverted transistor, the emitter power dissipation at cutoff for a given voltage is reduced by the same order of magnitude that I_P is reduced from the normal leakage I_P^N . This means that the transistor may be operated at a higher ambient temperature where I_P has increased to about the same value as the maximum allowable I_P^N , without causing thermal runaway. This temperature differential will allow about a 30°C higher working ambient temperature for transistor switches in the inverted-cutoff condition.

The inverted connection may be used where an extremely linear detector is needed from the millivolt region up to about $V_{ec} = -40$ volts. To keep a PNP transistor cut off, it is necessary to have the base a few tenths to a volt positive with respect to both junctions. If V_{ec} is positive, the transistor operates as in a normal common-collector circuit. The transistor can still be cut off, reducing the emitter load current to

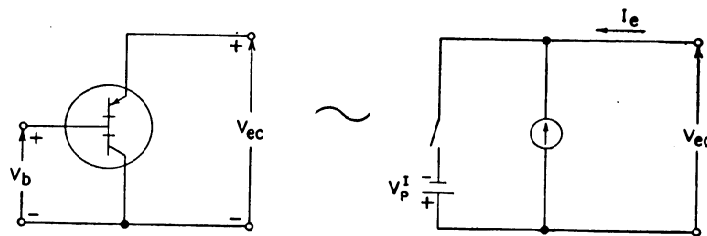

FIG. 16.31. Equivalent circuit for inverted transistor switch.

the value I_P , so long as the base voltage exceeds the emitter voltage by a few tenths of a volt. However, it is now necessary to have a base voltage in excess of V_{ec} since the base control voltage is referred to the collector. While capable of handling signals of relatively large magnitude, the inverted transistor is most useful in applications where the controlled voltages may be only 100 mv or less and where the introduction of spurious signals from the transistor equivalent battery and current source would be detrimental.

A simple and useful rule to keep in mind while analyzing the operation of switching transistor circuits is that a transistor will conduct in either direction as long as the base potential is such that either junction is biased in the forward direction. The transistor will be cut off as long as the base potential is such that both junctions are biased in the reverse direction.

16.5a. Choppers or Inverters. A simple chopper circuit consists of a single switching transistor in series with the source, as shown in Fig. 16.32a.¹¹ If the transistor were an ideal switch, this circuit would be equivalent to Fig. 16.32b. Here the input is alternately connected and disconnected to the output, and, therefore, the output voltage is a rectangular wave that alternates between zero and the value of the input voltage. Actually, the transistor is not ideal but is nearly equivalent to a battery V_P^I when conducting and a current source I_P^I when nonconducting. Thus, even if the

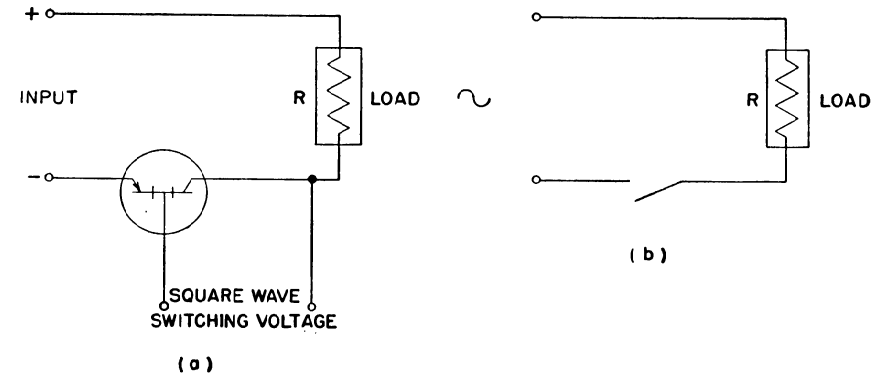

FIG. 16.32. Simple chopper circuit: (a) single transistor chopper; (b) ideal equivalent circuit.

input voltage is zero, a voltage of V_P^I will appear at the output during the conducting half cycle and a voltage $I_P^I R$ during cutoff. If this latter voltage is to be kept small, it means that R , the output load impedance on the chopper, must be small.

A slightly more complicated inverter circuit is shown in Fig. 16.33. First, consider the behavior of this circuit with the input shorted. The two half cycles can then be represented by the equivalent circuits in Fig. 16.34a and b. The current sources are effectively shorted by the batteries during both halves of the cycle, and the output alternates between V_{PA}^I and V_{PB}^I . If these two voltages are equal, the output is pure direct current and contains no a-c component. Figure 16.35 shows the variation of V_P^I for six NPN transistors as a function of temperature. Four of these transistors match with each other to within 150 μ v over a temperature range of -50 to +90°C, and two could be selected to match even more closely. For example, curves 1 and 5 match to within about 25 μ v for the same temperature range. This means that if transistors 1 and 5 were used in the chopper circuit of Fig. 16.33 and the input were shorted, the output a-c signal would be less than 25 μ v from -50 to +90°C.

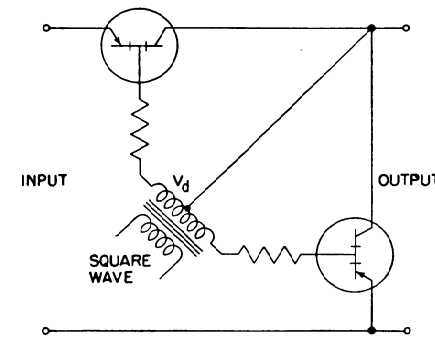

FIG. 16.33. Two-transistor chopper circuit.

If the input is not shorted but is connected to a source with an internal resistance R_o , the equivalent circuits are as shown in Fig. 16.36a and b. In a the output is still shorted by V_{PB}^I and hence I_{PA}^I has negligible effect. However, in b the effect of current generator I_{PB}^I is no longer negligible but, rather, produces a component of the output voltage equal to

$$I_{PB}^I \frac{R_o + R_L}{R_o R_L}$$

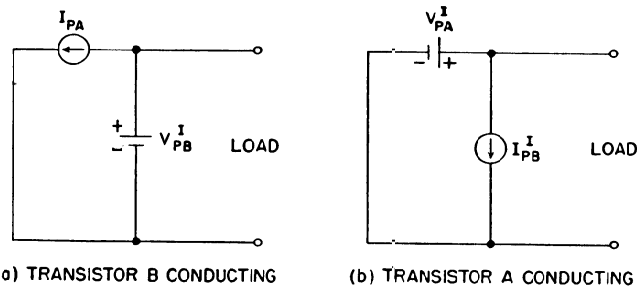

FIG. 16.34. Equivalent circuit of two-transistor chopper with the input short-circuited.

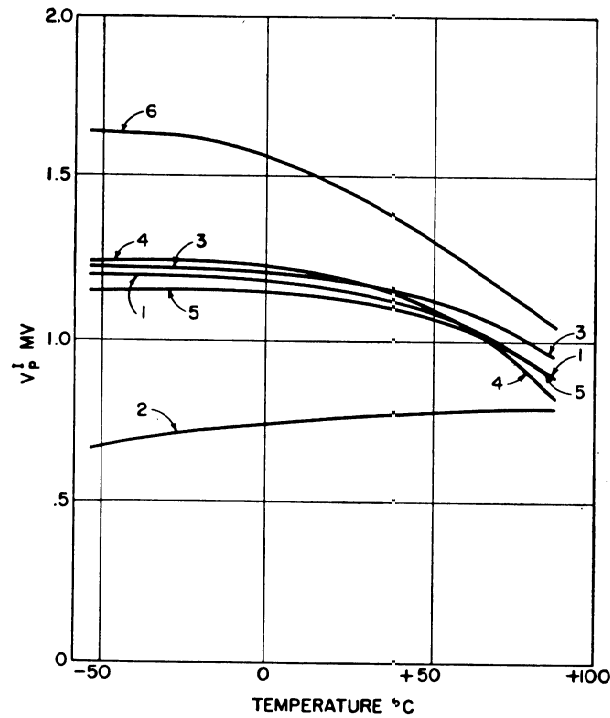

FIG. 16.35. V_P^I versus temperature for six NPN transistors. (Redrawn by permission of the American Institute of Electrical Engineers.)

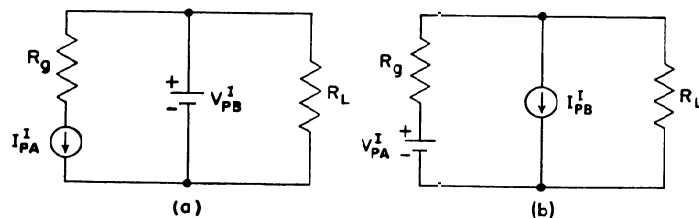

FIG. 16.36. Equivalent circuit of two-transistor chopper input impedance R_o .

If this potential is to be made negligible, either R_L or R_o must be small. If the source is a thermocouple, for example, then R_o will be very small and this extraneous term will ordinarily be negligible.

The input voltage of this inverter circuit may have either polarity, but its magnitude must be less than the base driving voltage V_d . If it is greater than V_d , one or the

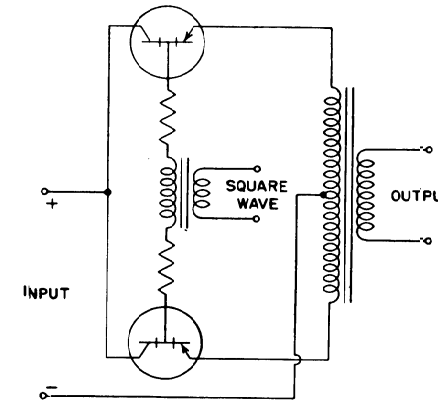

FIG. 16.37. Full-wave inverter with transformer output.

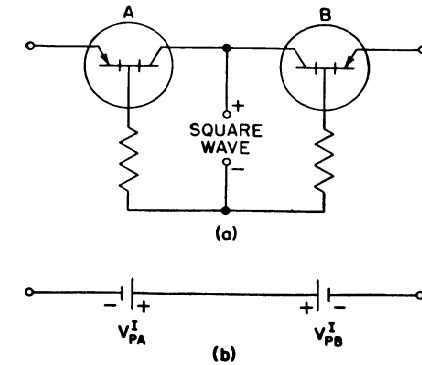

FIG. 16.38. A-C transistor switch: (a) switch capable of conducting or blocking either input polarity; (b) equivalent circuit of switch when conducting.

other of the transistors would not be cut off, as can be seen by applying the rule given at the end of the introductory section. A full-wave inverter using a transformer output is shown in Fig. 16.37.

Transistor inverters have sensitivities comparable with mechanical choppers. In a typical mechanical-chopper amplifier servo circuit with a servomotor as the output device, a d-c input of $6 \mu\text{v}$ operated the motor. After direct substitution of the transistor chopper in the same plug, a d-c input of only $8 \mu\text{v}$ was required to operate the motor, demonstrating that the threshold sensitivity is comparable.

16.5b. A-C Switch. The circuits discussed in the preceding section were intended to operate on a unidirectional input only. If the input voltage were reversed, the transistors would not block a voltage higher than the base drive voltage, as this would bias the emitter-base diode in the conducting direction, thus violating the rule for the cutoff condition. A circuit capable of passing and blocking alternating currents and voltages is shown in Fig. 16.38a. If the square wave has the polarity shown, the collector-base junctions are both biased in the forward direction, and, hence, both transistors will conduct current in either direction. The equivalent circuit for this half cycle merely contains the two batteries V_{PA}^I and V_{PB}^I in opposition, as shown in Fig. 16.38b. Thus, these potentials tend to cancel.

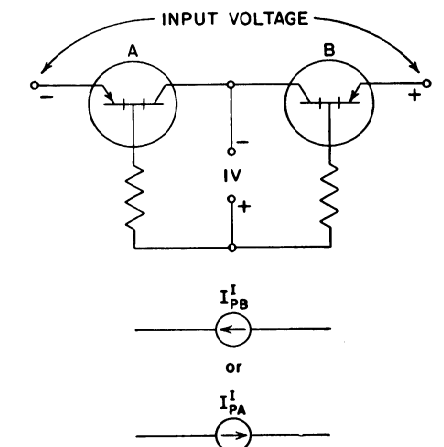

FIG. 16.39. A-C switch during blocking interval.

For the blocking condition let the polarities be as shown in Fig. 16.39. Here, both

collector junctions are biased in the reverse direction. The emitter of transistor *A* is also negative with respect to the base, and, hence, both junctions of *A* are biased backward and the circuit is cut off.

Similarly, if the controlled circuit potential reverses, transistor *B* has both junctions biased backward and, hence, blocks the circuit. The equivalent circuit for the cutoff condition is quite complicated, but if the controlled circuit potential is a volt or more and has the polarity shown above, the equivalent circuit is approximately the current generator I'_{PA} , and similarly it is the current generator I'_{PB} for the opposite polarity.

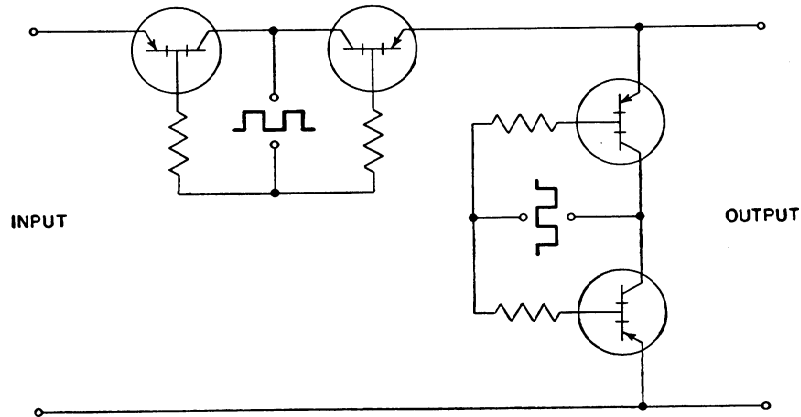

FIG. 16.40. Transistor chopper capable of operation with up to 40 volts input.

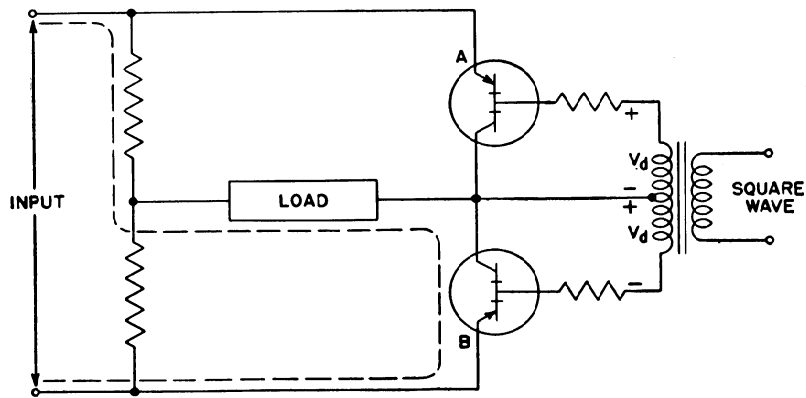

FIG. 16.41. Phase-sensitive detector.

A chopper that can be used with a source of either polarity and up to the breakdown potential of the transistors can be made using two such a-c switches, as shown in Fig. 16.40.

16.5c. Phase-sensitive Detectors. Figure 16.41 shows a two-transistor phase-sensitive detector circuit. The driving square wave establishes the phase reference. If the square-wave polarity is as indicated, transistor *B* will be conducting and transistor *A* cut off. Thus, the circuit will be completed as shown by the dashed line; the direction of the current will depend upon the polarity of the source. On the other half cycle, *A* will conduct and *B* will be cut off, thereby reversing the current path through the load. Thus, if the input is a sine wave whose zero crossings correspond

with those of the square-wave reference, the load voltage will be a full-wave rectified sine wave whose polarity reverses when the input phase changes by 180°.

The maximum allowable peak input voltage for this circuit is equal to the driving voltage V_d , for if the input exceeds this value, the transistors will no longer block. A four-transistor circuit which eliminates this restriction on the input voltage by using two a-c switches is illustrated in Fig. 16.42.

Both of these circuits require a low impedance source in order to assure that the leakage current of the nonconducting transistor will not cause an appreciable voltage drop

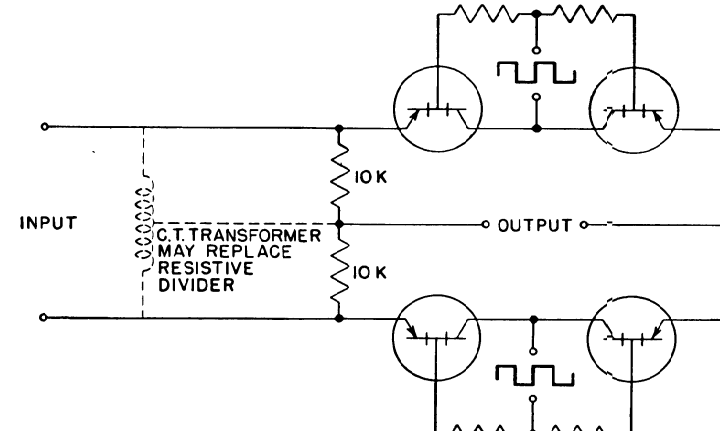

FIG. 16.42. Four-transistor phase-sensitive detector.

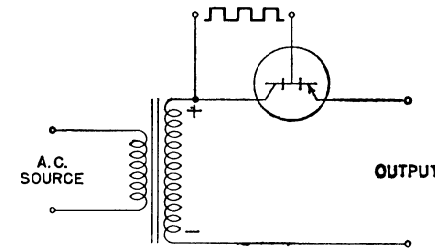

FIG. 16.43. Synchronous rectifier.

that will appear at the output. If a low impedance load is used, the input and output terminals may be reversed. The input voltage sensitivity is comparable to that of the chopper or inverter circuit.

It would also be possible to make a bridge-type phase-sensitive detector using four such two-transistor a-c switch combinations, or a total of eight transistors.

16.5d. Synchronous Rectifier. A synchronous rectifier which is nearly ideal down to the millivolt level is shown in Fig. 16.43. The square wave is synchronous with the voltage to be rectified and has the phase relation (or polarity) shown. When the base is positive with respect to the collector, it is thus also positive with respect to the emitter and the unit is cut off. The emitter blocks the supply voltage, and the leakage is reduced to the value of I'_P . When the base is negative with respect to the collector, the unit conducts with normal supply polarity and current gain and connects the source to the output. It is often satisfactory to obtain the driving source directly from the input so that a sinusoidal base drive may replace the square wave shown.

Figure 16.44 shows a comparison of the VI characteristics of a 1/4-in. selenium cell

and a PNP transistor connected as a synchronous rectifier. At a forward current of 20 ma the transistor rectifier drop is less than 0.1 volt while the selenium cell has a drop of 1.1 volt. The transistor base drive for making this comparison was about 5 ma from a 1.5-volt sinusoidal supply.

16-5e. Base-drive Considerations. The current-handling capability and the conduction resistance of a transistor are primarily a function of the base current and not the base voltage. Because of the fact that the base resistance may vary considerably from unit to unit, a number of transistors all having the same base voltage may have base currents differing by factors of 3 or 4. For this reason, a high resistance or a nearly constant-current driving source is advisable to saturate the closed transistor switch. To reduce the dynamic conduction resistance, a value of 5 or 10 ma base

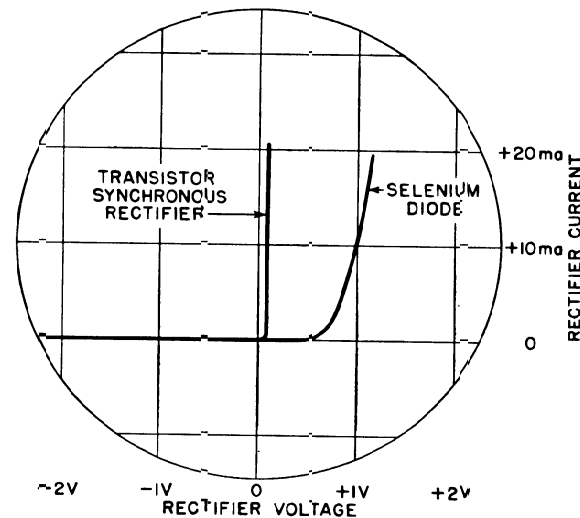

FIG. 16.44. Oscilloscope showing rectifier characteristics of transistor synchronous rectifier and $\frac{1}{4}$ -in. selenium cell.

current is advisable. The transistor can control a load current of $(\alpha_N/1 - \alpha_N)I_B$ in the normal direction and a current $(\alpha_I/1 - \alpha_I)I_B$ in the opposite direction. All the circuits shown have used the inverted connection because of the better low-level performance. For the inverted connection, a good rule is that the base current should not be less than the load current to be controlled and, if the dynamic resistance is to be kept low, should be at least 5 or 10 ma. For most low-level applications, the controlled currents will be on the order of a fraction of a milliamper, and, therefore, for most transistors and inverted gains encountered a current of 5 to 10 ma is satisfactory.

If currents of more than about 20 ma are to be controlled, it is advisable to use the normal connection at a sacrifice of low-level performance. (Note that since one or the other of the transistors in the two-transistor a-c switch pair described in Fig. 16.38 is always conducting in the inverted direction, regardless of the input polarity, this is inherently a low-current device.)

Most of the driving circuits shown here have been indicated as square waves. Satisfactory operation can often be obtained by using sinusoidal drive, although the waveforms involved are no longer simple and some disturbances may occur during the zero crossing interval.

One other precaution should be pointed out. Most commercial transistors are rated at about 45 volts. In most cases this rating applies only to the collector junc-

tion—the emitter-junction breakdown is not checked during manufacture. In the circuits described here, the high inverse voltage appears across the emitter junction, and, therefore, units should be individually tested for this breakdown characteristic before installation, or transistors rated for such switching applications should be obtained.

REFERENCES

1. Lesk, I. A., and V. P. Mathis: The Double Base Diode: A New Semiconductor Device, *IRE Convention Record*, part 6, p. 2, March, 1953.
2. Suran, J. J.: Double Base Expands Diode Applications, *Electronics*, vol. 28, No. 3, pp. 198-202, March, 1955.
3. Aldrich, R. W., and I. A. Lesk: The Double Base Diode: A Semiconductor Thyatron Analog, *Trans. IRE, PGED*, vol. ED-1, No. 1, p. 24, February, 1954.
4. Shockley, W.: A Unipolar Field Effect Transistor, *Proc. IRE*, vol. 40, No. 11, pp. 1364-1376, November, 1952.
5. Dacey, G. C., and I. M. Ross: Unipolar "Field-effect" Transistor, *Proc. IRE*, vol. 41, No. 8, pp. 970-979, August, 1953.
6. Huang, C., M. Marshall, and B. H. White: Field Effect Transistor Applications, presented at the AIEE-IRE-University of Pennsylvania Conference on Transistor Circuits, Feb. 17, 1955, to be submitted to the Institute of Radio Engineers.
7. Wallace, Jr., R. L., L. G. Schimpf, and E. Dickten: A Junction Transistor Tetrode for High-frequency Use, *Proc. IRE*, vol. 40, pp. 1395-1400, November, 1952.
8. Benjamin, C., and R. L. Longini: Double Diffused Hook Collector, IRE Conference on Semiconductor Devices, University of Pennsylvania, June, 1955.
9. Ebers, J. J., and J. L. Moll: Large Signal Behavior of Junction Transistors, *Proc. IRE*, vol. 52, pp. 1761-1772, December, 1954.
10. Bright, R. L.: Junction Transistors Used as Switches, *Trans. AIEE, Paper 55-156*, Communications and Electronics, No. 17, p. 111, March, 1955.
11. Kruper, A. P.: Switching Transistors Used as a Substitute for Mechanical Low-level Choppers, *Trans. AIEE, Paper 55-517*, Communications and Electronics, No. 17, p. 141, March, 1955.